

# GETM3.0Pro

许用径向载荷 Max. axle load	3000kg
曳引机概算重量 Motor weight	290kg
启动次数(次/小时) Start-up time	180
绝缘等级 Ins. class	155(F)
制动器型号及数量 Brake type	2只DZD2

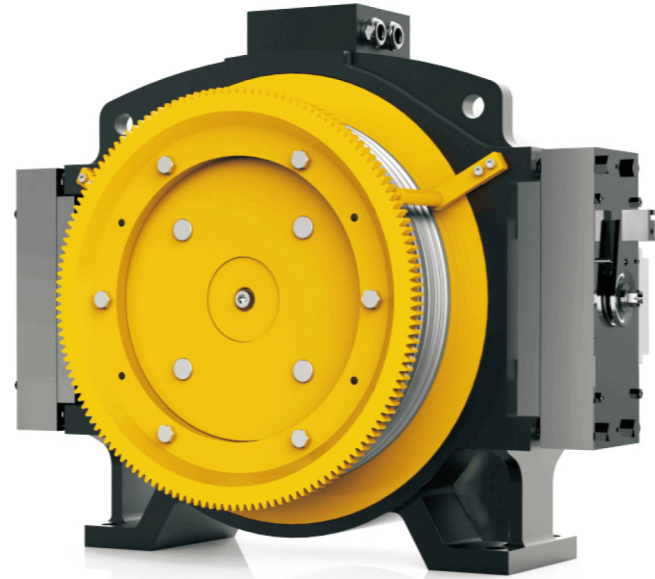

规格表 Specification table

型号 Product type	曳引比 Traction Ratio	额定载重 Load (kg)	额定速度 Elevator Speed (m/s)	额定转速 Rated Speed (r/min)	额定转矩 Rated torque (N.m)	电机 Motor					曳引轮 Sheave			制动器 Brake	
						功率 Power (kW)	电压 Voltage (V)	电流 Current (A)	级数 Poles (p)	频率 Frequency (Hz)	节径 Diameter (mm)	绳槽数 Rope (n)	槽距 Groove pitch (mm)	电流 Current (A)	电压 Voltage (V)
GETM3.0Pro-100/0800	2:1	800	1	96	500	5.0	340	13	30	23.9	400	≤6×φ10	15	≤2×1.5	DC110
1.5			143	511	7.7	19		35.8							
1.75			167	511	8.9	21		41.8							
GETM3.0Pro-100/1000	2:1	1000	1	96	604	6.0	340	15	30	23.9	400	≤6×φ10	15	≤2×1.5	DC110
1.5			143.0	639	9.6	23		35.8							
1.75			167	639	11.2	27		41.8							
GETM3.0Pro-100/1050	2:1	1050	1	96	634	6.3	340	16	30	23.9	400	≤6×φ10	15	≤2×1.5	DC110
1.5			143	669	10.0	23		35.8							
1.75			167	669	11.7	28		41.8							
GETM3.0Pro-100/0450	1:1	450	1	48	588	2.9	380	7.7	15	12	400	5×φ10	15	2×1.5	DC110

注：1、以上信息仅供参考，具体参数请以 ODF 表为准； 2、绳槽数量、β角、γ角可根据客户系统进行非标；  
 Note: 1. Above parameters for information only, final parameters shall be as per ODF. 2. Quantity of rope groove number, β angle and γ angle can be tailor-made according to customer's requests.

# 外形尺寸图 Overall Dimensions

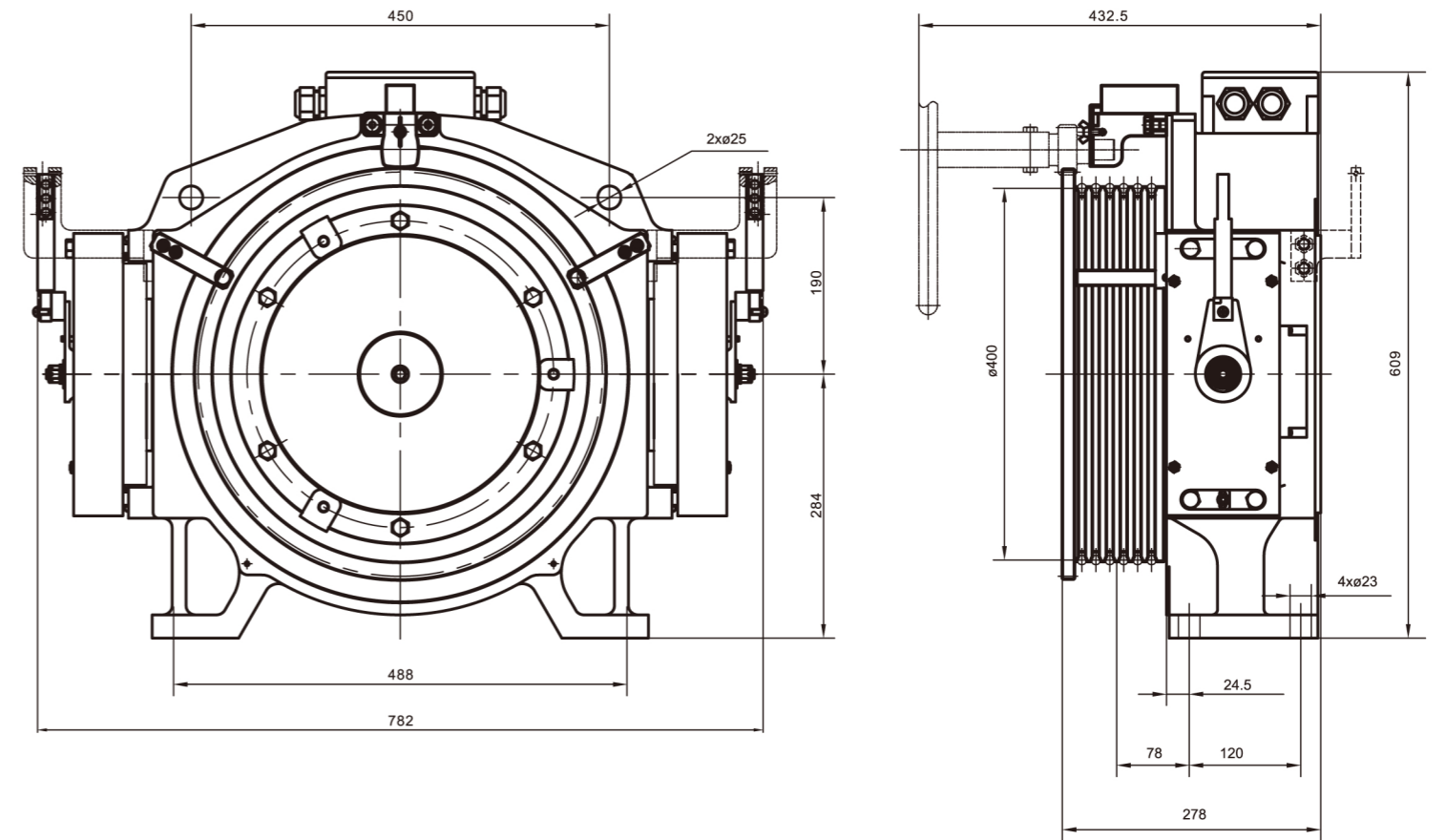

注：1、本机分为有盘车和无盘车两种状态；  
 2、可配备远程松闸装置，松闸线长 4~10 米。

Remarks:  
 1. Both hand wind and hand wind-less types are available.  
 2. Remote release device is available, the length of releasing wire ranges 4~10m.